

**STACK
STACK[®]
STACK**



Drag-Logger System Bracket, Sportsman and Pro

Users Guide

Input	Sensor Part #	Channel Name
PA1		
PA2		
PA3		
PA4		
A5		
A6		
A7		
A8		
A9		
A10		
PA11		
PA12		
PA13		
PA14		
A15		
A16		
A17		
A18		
A19		
A20		
PA21		
PA22		
PA23		
PA24		
A25		
A26		
A27		
A28		
A29		
A30		
PA31		
PA32		
PA33		
PA34		
A35		
A36		
A37		
A38		
A39		
A40		

Preface

Congratulations

Congratulations on choosing the Stack Drag-Logger System. This system will give you a wealth of information to enable you to obtain the maximum safe performance from your vehicle.

Registration Form

Please complete and return the registration form contained in the package. This will allow us to keep you up to date on the latest developments from Stack.

Purpose of this manual

This manual will help you install and use the Stack Drag-Logger System. It explains how to set up and configure the system for your vehicle.

! Important: As you install the system on your vehicle, please use the worksheet on the previous page to note the connections made on your system. This will save you time later when you build your system configuration in DataPro Designer or if you need to perform any system maintenance at a later date.

Stack ® is a registered trademark of Stack Limited.

Information in this publication is subject to change without notice and does not represent a commitment on the part of Stack Limited. No responsibility is accepted for error or omission.

Copyright © 2008 Stack Limited

Related Products From Stack Limited

If you need information about other Stack motor sport products, these can be obtained from Stack or from your local Stack dealer. Products available from Stack include:

- Intelligent Tachometers
- Boost Gauges
- Analogue Sensors
- Digital Sensors
- Data Logging Systems
- Display and Logging Systems
- Radio Telemetry Systems
- Display and Analysis Software
- Video Overlay Systems
- Solid-state Video Recorders

Contents

Preface	i
Related Products From Stack Limited	ii
Contents	iii
Chapter 1. Introducing the Drag-Logger	1
How to use this Manual	2
Chapter 2. Getting Started	3
The Bracket Drag-Logger Module	5
The Sportsman Drag-Logger Module	5
The Pro Drag-Logger Modules	5
A1 Sensor Wiring Harness	6
B1, A2 and B2 Sensor Wiring Harness	6
Network Wiring Harness	6
Connecting the Components	7
Testing the Initial Set-up	8
Chapter 3. Installing the Drag-Logger	10
Who can install the Drag-Logger?	10
Tools needed to install the Drag-Logger	10
Fitting the Drag-Logger Module	10
Switches	11
Recording Status Light	12
Shift Lights (optional)	13
Single Shift Light	13
ST539 Multi-Stage Shift Light Module	14
Engine Speed (RPM) Measurement	14
Wheel speed and transmission sensors	16
Fluid Pressure Sensors	17
AMP9546 Vacuum Sensor	17
Fluid Temperature Sensors	18
Exhaust Gas Temperature Sensors (EGT)	19
Position Sensors	19
Hydraulic Pressure Sensors	21
Wiring harness	23
Chapter 4. CAN Gauges (optional)	25
Installing the CAN Gauges	25

Peak Values (Tell Tales)	25
Alarms	26
Chapter 5. Using the Drag-Logger	28
Configuring the system	28
Checks and Alarms	28
Recording Data (Data Logging)	29
Calibrating Sensors	30
Appendix A. Main Wiring Harness	31
Appendix B. Sensor Wiring Harnesses	32
Appendix C. Network Wiring Harness	33
Appendix D. Switch Functions	33
Appendix E. Light Functions	33
Appendix F. Service and Support	34
Index	35

Chapter 1. Introducing the Drag-Logger

The Stack Drag-Logger System can monitor a range of values, known as performance parameters, needed for effective car and driver management in most competitive situations.

The system consists of a ten input sensor module with a built-in two megabyte data recorder.

The system also provides a gearshift warning light that illuminates above an RPM value that you define for your vehicle.

All of the sensors may be recorded at rates up to 500 samples per second (500 Hz). Data recording can be configured to start when a parameter, eg, Engine Speed, rises above a preset value.

The recorder can hold thirty Runs and those runs can be downloaded to you PC using the Stack DataPro software (see separate Users Guide).

How to use this Manual

Stack recommends that you unpack and connect the components in the system **before** you install it in your vehicle. This will enable you to familiarise yourself with operating the system and configuring it for the vehicle in which you intend to install it.

This manual starts by taking you through the process of checking the system before installation, installing it in your vehicle, configuring the system and finally using it.

- ! *This manual does not attempt to explain how to interpret or use the information from the Drag-Logger System as this is very specific to the type of vehicle in which it is installed and the type of competition in which that vehicle is engaged.*

Chapter 2. Getting Started

This chapter guides you through the initial unpacking and setting-up of the equipment for pre-installation checks and familiarisation with its operation.

Standard Drag-Logger Items

The Drag-Logger System is supplied with the following standard components:

Bracket System

Quantity	Description
1	Bracket Drag-Logger Module (ST834-202)
1	Network Harness Type 1 (ST995018)

Sportsman System

Quantity	Description
1	Sportsman Drag-Logger Module (ST834-302)
1	Network Harness Type 1 (ST995018)

Pro System

Quantity	Description
2	Pro Drag-Logger Modules (ST834-302 & ST834-402)
1	Network Harness Type 2 (ST995019)

All Systems

Quantity	Description
3	Internal G sensors
1	CAN Gauges Terminating Cable (ST918100)
1	CANUSB Network Interface (ST995010)
1	Sensor Harness Type 1 (ST995011)
3	Driver, Recording & Reset Switches (ST517)
1	Recording Status Light (ST536)
1	Mini Sure-Seal Receptacle Kit (ST582)

1	Engine Speed Interface (ST493)
1	ES Extender Harness (ST918024-101)
1	6ft Harness Extender (ST995003)
1	10ft Harness Extender (ST995005)
1	DataPro Software (ST920033)
1	DataPro Quick-start Guide (ST542095)
1	Drag Logger User Guide (ST542094)

Optional Drag-Logger Items

The Drag-Logger System can be used with the following optional components:

Quantity	Description
1	5 LED Multi-Stage Gear Shift Warning Light (ST539)
or	Single Gear Shift Warning Light (ST534 or ST537) and (ST918081) adapter cable
1	Sensor Harness Type 2 for Sportsman system (B1 : ST995012)
3	Sensor Harness Type 2 for Pro system (B1 : ST995012, A2 : ST995013 and B2 : ST995014)
	Various sensors to suit your needs
	CAN Gauges to suit your needs

The Bracket Drag-Logger Module

The Bracket Drag-Logger Module consists of a compact cast aluminium module. That module is connected to up to ten sensors by a wiring harness with a 19-way military connector. A second wiring harness with a 4-way military connector is used to connect power to the module, for connecting CAN gauges and for downloading data to a PC.

The Sportsman Drag-Logger Module

The Sportsman Drag-Logger Module consists of a similar module to the Bracket system except that it has two 19-way military connectors. That module is connected to up to twenty sensors using two wiring harnesses. A third wiring harness with a 4-way military connector connects the module to the CAN network and power.

The Pro Drag-Logger Modules

The Pro Drag-Logger Modules consist of two compact cast aluminium modules. Those modules are connected to a variety of sensors by up to four wiring harnesses with 19-way military connectors. A fifth wiring harness with 4-way military connectors is used to connect the two modules together to provide power, for connecting CAN gauges and for downloading data to a PC.

A1 Sensor Wiring Harness

Each of the wires in this harness is labelled:-

Label	Connection to
RL	Recording light
SL	Gear shift light
S1,S2,S3	Switches 1, 2 and 3
PA1	Engine speed (RPM) or 5 volt sensor
PA2 to PA4	Pulse or 5 volt sensors
A5 to A10	5 volt sensors

B1, A2 and B2 Sensor Wiring Harness

Each of the wires in these optional harnesses is labelled:-

Label	Connection to
PAX1	Engine speed (RPM) or 5 volt sensor
PAX2 to PAX4	Pulse or 5 volt sensors
Ax5 to Ax0	5 volt sensors

Network Wiring Harness

Each of the wires in this harness is labelled:-

Label	Connection to
B+	Battery positive (9 – 30 volts)
B-	Battery negative (Earth)
unlabelled	CANUSB connection to PC
unlabelled	CAN connection to CAN Gauges

Connecting the Components

Refer to the diagram below which shows the wiring for a Bracket Drag Logger. The Sportsman and Pro systems only differ in that they can have extra sensor harnesses and the Pro has two modules:-

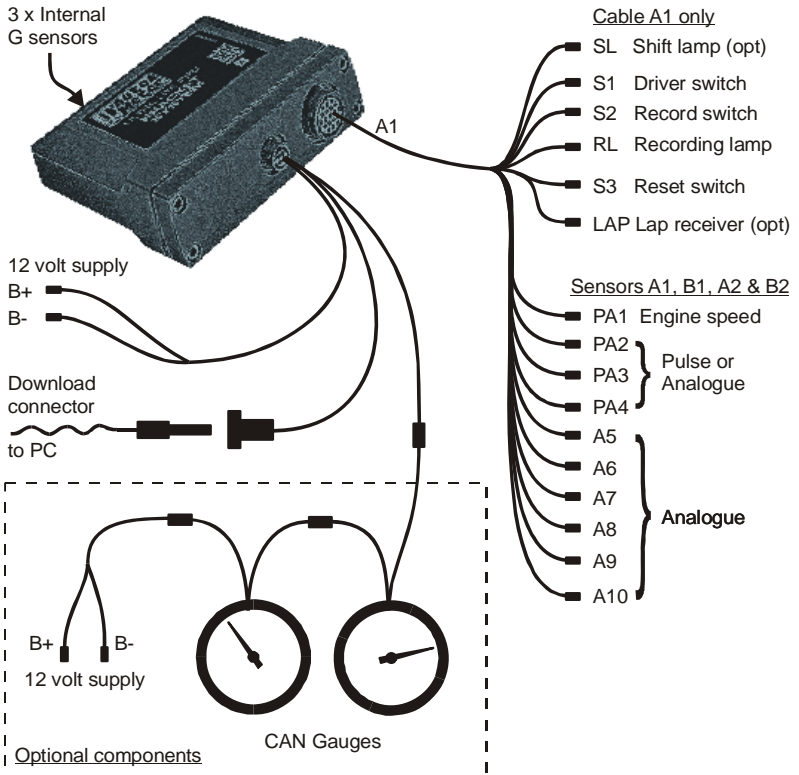

1. Connect the wiring harnesses to the Drag-Logger Modules. Ensure that the large label on each cable matches the name printed on the module labels, eg, A1, B1, A2 and B2.
2. Connect the three switches to the wires labelled S1, S2 and S3 on the A1 cable.

3. Connect the Recording Light to the wire labelled RL.
4. Connect the optional Multi-stage Shift Light or Single Shift Light to the wire labelled SL.
5. Connect each of the sensors that you have purchased to the appropriate wire in the wiring harness. The first four sensor connections (PAX1 to PAX4) can handle either Pulse or Analogue (5 volt) sensors. The remaining six connections (Ax5 to A10) can only handle Analogue sensors.
6. Connect a 12v DC power supply to the power input cable, eg, from a car battery. B+ is battery positive and B- is battery negative. Protect this B+ line with a 3 amp fuse.
7. Connect any CAN Gauges you have to the network harness. Connect the short battery cable to the other end of that chain and connect it to the power supply. Protect this B+ line with a 5 amp fuse.
8. Switch on the 12v DC power supply.

If you have a Sportsman system, there is a Main Harness and an optional Sensor Harness. The main harness connects to port A1 and the sensor harness to B1.

If you have a Pro system, there are two separate modules designated 1 and 2. Connect the A1 Main Harness and the optional B1 Sensor Harnesses to module 1 as described above. Connect the two remaining optional sensor harnesses to ports A2 and B2 of module 2. Join the two modules together using the Network Harness provided.

You can now proceed to familiarise yourself with operating the Drag-Logger Module.

Testing the Initial Set-up

You will have switched the system on already if you have followed the instructions in the previous chapter

and have just set the system up for the first time before installing it.

- ! *When installed in the vehicle, the system is switched on when you switch the ignition on.*

When the power is first switched on, very little will appear to happen. The optional CAN Gauges will reset themselves by moving their needles until they touch the stop-pin and then moving back to the zero position. The CAN Gauges should now show the values of the sensors which are connected.

The analogue dial face should be backlit when the system is switched on. If any of the gauges are illuminated red, press the Driver Switch to clear the warning/alarms.

Testing Switch Operations

Pressing the Recorder Switch should cause the Recording Light to illuminate. Pressing that switch again will turn the light off.

Pressing the Reset Switch should cause the Recording Light to flash once for each press. Note that ten seconds or more must elapse before it is possible for this action to happen again

Chapter 3. Installing the Drag-Logger

This chapter guides you through installing it in the vehicle.

Who can install the Drag-Logger?

The Drag-Logger can be installed by anyone competent in fitting electrical and mechanical accessories to cars.

Tools needed to install the Drag-Logger

No special tools other than normal workshop tools are required.

Fitting the Drag-Logger Module

The Drag-Logger Module should be fitted to a rigid part of the chassis which is not prone to movement or vibration caused by the engine or suspension. There should be ample space around the module to allow access for installation and maintenance.

Ensure that there is sufficient space near the connectors to allow the sensor wiring harnesses to be connected to the 19-way connectors without any tight bends to the wiring near the connector.

In order to get the most accurate results from the internal G sensors, the Drag-Logger Module should be aligned so that it is as close as possible to the three main axes (X, Y and Z) of the vehicle. The DataPro Designer Calibration function allows any minor out-of-axis errors to be corrected but it cannot be used to correct alignment errors of more than five degrees.

Using the Dual-Lock Fastener

This is a high opening force *Velcro-type* fastener system with identical mating halves. It is intended for semi-

permanent fixing applications and should not be used for parts which require frequent dismantling.

For best performance, the following precautions should be taken:-

- Bond strength is dependent upon the amount of adhesive to surface contact. Firm application pressure develops better adhesive contact and thus improves bond strength.
- To obtain maximum adhesion, the bonding surfaces must be clean, dry and smooth. Typical surface cleaning solvents are isopropyl alcohol/water mixture (rubbing alcohol) or heptane. Use proper safety precautions when handling solvents.
- Ideal application temperature range is 21°C to 38°C (70°F to 100°F). Initial application to surfaces at temperatures below 10°C (50°F) is not recommended because the adhesive becomes too firm to adhere readily.
- Take one piece of Dual-Lock fastener, remove its backing and attach to the sensor or module.
- Take a second strip of the fastener and, ensuring correct alignment, attach it to the first piece by pushing them together firmly.
- Remove the backing from the second strip of fastener and attach the sensor or module to the vehicle in the desired position. Push against the fastener firmly to ensure maximum adhesion.



Do not try to separate the two strips of fastener immediately. The acrylic adhesive backing should be given at least 24 hours to achieve full bond strength.

Switches

The three switches are used to control the functions of the Drag-Logger.

The normal functions of the switches are:

Switch	Functions
Switch 1	Show Peak Values or Clear Alarms (optional CAN Gauges)
Switch 2	Toggle recording

You can install the switches in any convenient location. When installing the switches, you should take account of the following considerations:

- Drill a half inch hole in a suitable panel or manufacture a bracket with a hole in it.
- Insert the switch from the reverse side of the panel and screw on the rubber cover from the front. Do not over-tighten the nut; just greater than hand-tight should be enough.
- The cable for each switch is approximately 400 mm (16") in length from the 19-way military connector so use extender cables if necessary.
- If using the optional CAN Gauges, it is important that the driver is able to reach Switch 1 easily in order to show peak values and to clear alarms. This switch is normally fitted on the steering wheel.

Recording Status Light

The Drag-Logger Module has a light which, when illuminated, indicates that data is being recorded, ie, data logging is in progress.

The recording light should be installed in a position so that it is visible to the driver and/or to the pit crew.

- Drill a half inch hole in a suitable panel or manufacture a bracket with a hole in it.
- Pass the light through the hole from the viewing side.
- Thread the plastic nut over the two wires and tighten it on to the light. Do not over-tighten the nut; just greater than hand-tight should be enough.

- Connect the wires to the RL cable on the sensor harness using an extension cable if necessary.

! *If you are using your own warning light, ensure that the bulb rating does not exceed 2 Watts otherwise the Drag-Logger Module will be damaged.*

Shift Lights (optional)

The Drag-Logger Module has the ability to illuminate a light to indicate it is time to change up a gear. The gear shift light comes on when the engine RPM exceeds a predefined values. See Chapter 4, *Configuring the Drag-Logger* for information about setting this value.

Two types of gear shift lights may be fitted as described below.

Single Shift Light

The Single Shift Light which, when illuminated, indicates that it is time to change up a gear.

The light should be installed in a position so that it is visible to the driver while seated in the car.

- Drill a half inch hole in a suitable panel or manufacture a bracket with a hole in it.
- Pass the light through the hole from the viewing side.
- Thread the plastic nut over the two wires and tighten it on to the light. Do not over-tighten the nut; just greater than hand-tight should be enough.
- Connect the wires to the SL cable on the sensor harness using the adapter harness supplied with the light.

! *If you are using your own warning light, ensure that the bulb rating does not exceed 2 Watts otherwise the Drag-Logger Module will be damaged.*

ST539 Multi-Stage Shift Light Module

This module contains five high-brightness LEDs which illuminate in turn as the engine RPM increases. The set-points for each LED are configured using DataPro Designer (see separate User Guide).

- Site the Multi-Stage Shift Light Module in front of the driver so that the LEDs can be seen while seated in the car.
- Mount it using the Dual Lock™ tape supplied or use the M3 tapped holes (10 mm maximum depth) in the body of the Shift Light Module.
- If you wish to take advantage of the night-time illumination level, mount the push-button Dimmer Switch within easy reach of the driver. Pressing that switch toggles between pre-set high and low brightness levels.
- Identify the ‘SL’ wire on the Drag-Logger harness. Connect the mini sure-seal connector on the shift light harness to this wire.

Engine Speed (RPM) Measurement

The engine speed (RPM) is measured by connecting the engine speed wire directly to the ignition system. A single wire from the connector labelled PA1 connects the Drag-Logger to the ignition system.

! *The PA1 input has special properties which will reject noisy signals making it ideal for connecting to engine speed signals, particularly signals obtained from magnetos. For this reason Engine speed signals should not be connected to PA2 to PA4.*

Connecting the Drag-Logger to the ignition system

The Drag-Logger can be connected to engines with a variety of ignition systems as shown in the table below:

Ignition System	Connection Point
ECU / Ignition Box	Direct to tachometer output
Coil and Points	Use adapter (ST493) to connect to the coil negative (low tension) terminal
HT coil lead	Use HT pick-up (ST697)

The following connections are shown in greater detail:

- Electronic ignition, ECU connection, CDI ignition (MSD, Mallory.....)
- Standard contact breaker system
- Contact breaker series resistor connection

Electronic Ignition or ECU Connection

Connect the PA1 wire directly to the “Tacho” output of the electronic ignition or Engine Control Unit.

The signal can be either a 5 volt or 12 volt pulse.

Standard contact breaker system

Connect the PA1 wire to the negative terminal on the coil using a ST493 ESPD Interface cable.

! Do not connect the PA1 cable directly to the coil or the Drag-Logger Module will be damaged.

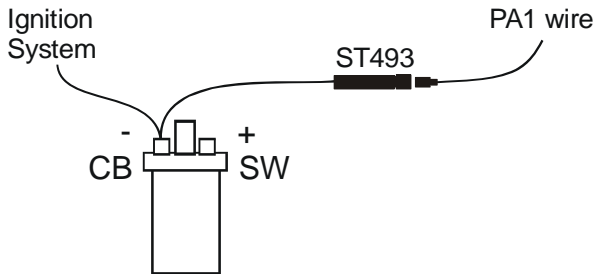

! Ensure the ignition system wire is held away from the ST493 wiring for greater than 100 mm (4 inches).

For systems which require a series resistor on the PA1 wire, a 10 KOhm $\frac{1}{2}$ watt resistor must be connected directly to the terminal to limit interference from the high tension leads (which must be the screened type).

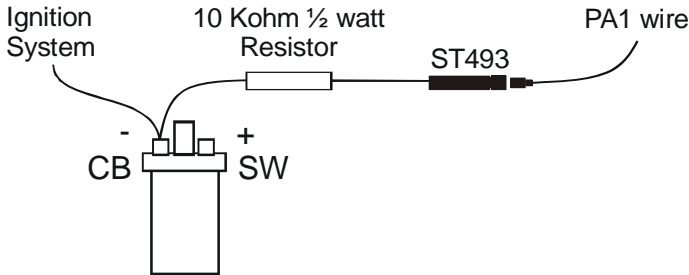

Wheel speed and transmission sensors

The Drag-Logger can be connected to a range of sensors to measure, for instance, wheel or transmission speeds. These sensors are used to measure wheel or shaft rotation in order to record the speed in MPH or RPM. The sensor provides an electrical pulse to the system each time a magnet passes near to the end of the sensor. When configuring the system you need to supply the number of magnets that will be counted for each revolution. In addition for speed you must supply the circumference of the wheel using Designer's Calibration facility.

Fluid Pressure Sensors

The Drag-Logger can be connected to a range of fluid pressure sensors to measure, for instance, Oil Pressure and Fuel Pressure.



Fitting the pressure sensors

- Position the sensors and their cables as far as possible from all sources of intense heat and from the ignition HT leads.
- Each sensor can either be screwed in directly to the monitoring point or fitted separately by using a suitable pressure hose to connect it to the monitoring point.
- Do not screw the sensor directly into the engine block because excessive vibration from some racing engines can affect the long-term life of the sensor.
- Do not over-tighten the sensor.
- Plug the sensor's Mini Sure-Seal connector into any of PA1 to PA4 and A5 to A10 of the Sensor Harness.

AMP9546 Vacuum Sensor

This sensor is designed to measure relatively low pressures such as those generated by inlet manifold depression.



Fitting the vacuum sensor

- Position the sensor and its cable as far as possible from all sources of intense heat and from the ignition HT leads.
- Mount the sensor on the chassis close to the place where the measurement is to be taken using small bolts or self-tapping screws through the sensor's mounting holes.



Do not mount the sensor onto the engine block because excessive vibration from some racing engines can affect the long-term life of the sensor.

- Connect the sensor to the measurement point using 8 mm (5/16") ID vacuum hose. Ensure that the pipe is connected to the Vacuum port and that the Pressure port is left open to provide an atmospheric pressure reference.
- Plug the sensor's Mini Sure-Seal connector into any of PA1 to PA4 and A5 to A10 of the Sensor Harness.

Fluid Temperature Sensors

The Drag-Logger can be connected to a range of temperature sensors to measure, for instance, Water Temperature and Oil Temperature.



Fitting the temperature sensors

- Position the sensors and their cables as far as possible from sources of intense heat and from the ignition HT leads.
- Mount each temperature sensor directly in the appropriate fluid line. Screw the sensor into a suitable mounting boss so that its tip lies near the middle of the flow of fluid.

- Plug the sensor's Mini Sure-Seal connector into any of PA1 to PA4 and A5 to A10 of the Sensor Harness.

Exhaust Gas Temperature Sensors (EGT)

The Drag-Logger can be connected to a range of K-Type thermocouple sensors to measure, for instance, Exhaust Gas Temperature. These typically measure temperatures from zero up to 200°C (400°F) or 1100°C (2000°F).

Position Sensors

The Drag-Logger can be connected to a range of position sensors for measuring throttle, steering or damper movements.

Plug the sensor's Mini Sure-Seal connectors into any of PA1 to PA4 and A5 to A10 of the Sensor Harness.

Rotary throttle position sensor

This sensor is designed to be fitted to the end of throttle butterfly shaft. Universal mounting holes are provided to allow the sensor to be bolted on to most standard throttle bodies.

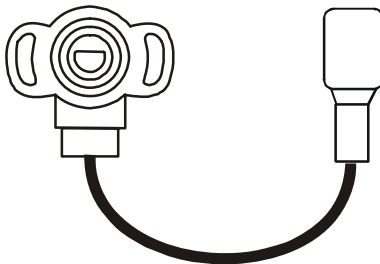

- ! *This sensor is not designed to take radial loads and must be carefully aligned with the centre line of the throttle shaft. Misalignment will shorten the life of the sensor.*

Rotary position sensor with arm

This sensor has a spring loaded lever which should be attached using a length of stranded wire to, for instance, a throttle pedal.

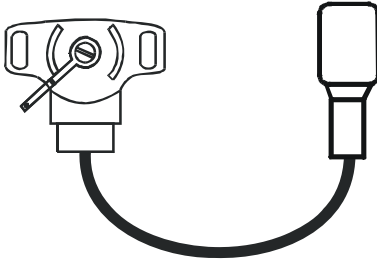

1. Find a mounting position which does not interfere with the drivers feet or operation of the controls.
2. Once the intended location for fixing is determined, drill 4.5 mm (3/16") holes to provide clearance for the supplied bolts
3. Bolt the sensor in place and connect it to the wiring harness
4. Using the length of cable supplied, pass the end of the cable through the hole in the lever arm and attach the other end to the side of the pedal lever.
5. Adjust the cable tension until the lever arm is just pulled away from its resting position. This adjustment should be checked regularly to remove any slack in the cable which may give rise to errors in throttle position.

Linear Displacement Sensors

The linear displacement sensor should be mounted between the vehicle's chassis and a suspension member. These sensors are available with various maximum displacements to suit different suspension systems.

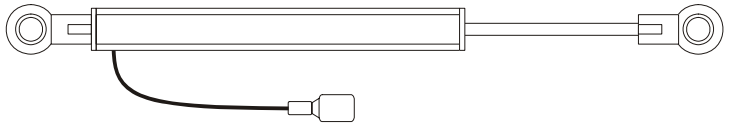

1. Find mounting positions on the suspension members and the adjacent chassis.
2. Once the intended location for fixing is determined, drill 5 mm (3/16") holes and fit suitable bolts.
3. Attach the sensor body to the chassis and the extending arm to the suspension.
4. Connect the sensor cable to the wiring harness.

! *The spherical bearings at each end of the sensor are designed to absorb any bending forces on the sensor rod and should not be restricted in any way. Failure to do this will result in bending forces being applied which will cause the sensor to fail.*

! *The sensor will be damaged if it is allowed to extend or compress beyond its normal range of movements.*

Hydraulic Pressure Sensors

The Drag-Logger can be connected to a range of hydraulic pressure sensors to measure, for instance, Brake Pressure or Wheelie Bar Pressure. These sensors can also be used to measure compressed gas pressures such as Nitrous Oxide (NOS).



Fitting the pressure sensor

! *Reliable braking performance is vital to the safe operation of your vehicle and only a competent mechanic should attempt to fit this sensor. Only high pressure brake line quality fittings should be used.*

- Position the sensor and its cable as far as possible from all sources of intense heat and from the ignition HT leads.
- The sensor has a Dash 3 female thread. Use a suitable adaptor to join it to a three-way connector block inserted into the brake line.

Wiring harness

The Drag-Logger Module and the sensors, switches and lights for your Drag-Logger are connected together by means of the wiring harness and sensor extender cables supplied with the system or the sensors.

The wiring harness can be fitted after the Drag-Logger Module and all the sensors and switches have been installed.

The sensor harnesses have short cables terminated with Mini Sure-Seal connectors. Likewise the sensors have short cables terminated with the mating connector. Since neither of those short cables is likely to be long enough to reach the sensors in their installed positions, you will need to bridge the gap using extender cables which are available from your dealer in a variety of lengths.

Fitting the wiring harness

When fitting the harness on the vehicle, you should observe the following:

- Start by attaching the sensor harness to the Drag-Logger Module by connecting the 19-way military connector.
- First position the ends of all the wires at the locations of the sensors, lights and switches to which each is to be connected, but do not connect them yet.
- All wires should be as far as possible and not less than 75 mm (3 inches) from sources of heat and electrical noise such as exhaust pipes, ignition HT leads, distributor caps etc.
- When you pass any wire through a bulkhead or dashboard, fit a cable gland into the hole so that the edge of the hole cannot chafe the wire.



Particular care is needed when passing wires through holes in carbon fibre as the carbon can cut through cables very easily.

- The download jack socket (the NET connector) should be mounted to the vehicle through a one inch (25.4 mm) diameter hole. It should be positioned so that it is easily accessible to the PC for downloading data when the vehicle comes into the pits. Packing washers are provided to ensure the socket is securely mounted.
- Connect the wires when all the sensors are in position and you have secured the wiring harness.

Mini Sure-Seal Connectors

The Drag-Logger Module connects to its sensors via four way ITT Cannon Mini Sure-Seal (MSS) connectors. A plug (the smaller of the two connectors) can be found on the ends of the Sensor Harness and a receptacle on the cable from the sensor. The following polarity is observed in all cases:

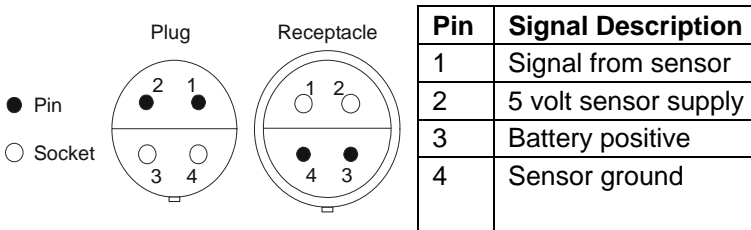

Mini Sure seal connectors offer excellent vibration and waterproof performance. However they do not have a positive locking mechanism so must not be subject to bending or pulling load, as such loads can cause the connector to fail.

Chapter 4. CAN Gauges (optional)

CAN Gauges are optional components which are designed specifically to work alongside the Drag Logger range of products. A range of gauges is available to display sensor values for most of the mainstream engine parameters, eg, engine RPM, water and oil temperatures, oil pressure, battery voltage and many more.

They are also capable of displaying warnings and alarms for each parameter being shown.

Installing the CAN Gauges

Please refer to the instructions supplied with the individual gauges.

Peak Values (Tell Tales)

The Drag Logger System can display the peak values (sometimes called 'tell-tales') that have been recorded during a run for all the displayed parameters.

Peak values are updated only when the engine speed has exceeded its fixed 'gate value' of 3000 RPM *for at least one second* which allows the values to stabilise. Blipping the engine may not be enough to update the peak values. This is to prevent abnormal peak values from being recorded when, for example, the engine is either not running, is idling or is being warmed up.

Displaying the Peak Values

Press and hold Switch 1 to show the peak values for the parameters currently being displayed on the CAN Gauges. Release the switch to return to the normal display.

Resetting the Peak Values

You can reset all of the peak values manually. If the engine is running **at** or **above** its gate RPM when the

peak values are reset, they are set to the current value of each performance parameter.

If the engine is running **below** its gate value, the peak values are not reset to the current values but are set to full-scale values appropriate for the type of peak which has been chosen.

To reset the peak values:

- Press and hold Switch 1 to display the peak values.
- While holding Switch 1, press and hold the Reset Switch.
- With the Reset Switch held down, you will see the CAN gauges revert to the current values. The new peak values that are stored are those being displayed when you release the Reset Switch.

Alarms

The Drag-Logger has the ability to show warnings and alarms to alert the driver when certain parameters either exceed or fall below their alarm values. For example, a warning may be issued if the fuel pressure falls below its alarm value or if the oil temperature rises above its alarm value. You can adjust the preset alarm levels when you configure the Drag-Logger using DataPro Designer.

You can configure the warnings so they are triggered only while another parameter is above or below a defined value, eg, while the engine speed exceeds a certain RPM. Blipping the engine should not be enough to trigger a warning. This helps to prevent abnormal warnings from being triggered when, for example, the engine is either not running, is idling or is being warmed up.

Displaying an Alarm

When an alarm condition occurs, the built-in red warning light turns on. If the sensor value is more than 10% above or below the alarm set-point, the red lamp will flash.

Clearing an Alarm

Press Switch 1 while alarms are being displayed to clear those alarms.

Chapter 5. Using the Drag-Logger

Configuring the system

Before using the Drag-Logger it must be configured to work with the sensors and optional parts you have installed. This is performed using the DataPro Designer program.

There is no limit to the number of times a configuration can be uploaded into the Drag Logger. So, as your system changes over time, perhaps by adding new sensors, changing the recording rates of existing sensors or modifying the alarm set-points of optional CAN Gauges, new configurations can be created. This makes the Drag Logger a very powerful tool since it is so easy to adapt it to new environments.

Details of how to install the DataPro suite of software and how to use Designer to configure your Drag Logger is described in separate User Guides supplied with your system.

Configuration Memory

The uploaded configuration is stored in non-volatile memory so that it is retained when the external power source is disconnected from the system.

If, after several years, the configuration (and any recorded data) is lost when the system is powered down, it is likely that the internal back-up battery will need replacing. In that case the Drag-Logger Modules should be returned to Stack for a service during which their internal batteries will be changed.

! *Ideally the modules should be returned every 4-5 years to ensure no loss of data.*

Checks and Alarms

You should check the system to ensure that all the sensors are detecting the correct values. This is

accomplished using DataPro's Real-Time Display function. You should run the engine up to its operational levels to check that the values displayed are accurate.

If using the Optional CAN gauges, you should then check out the alarm systems to ensure that they are functioning correctly before going out on to the track.

Recording Data (Data Logging)

Recording can be set to start automatically when the Engine Speed exceeds a pre-defined RPM set using DataPro Designer. The Drag-Logger records channels at the rates chosen in Designer. When setting the recording rates Designer indicates the maximum amount of recording time which is possible with those rates.

Whenever recording starts the Recording Light will illuminate. That light will go out when recording stops.

The Drag-Logger System can record up to 30 runs of data. No more recording is allowed if the memory is full or the maximum number of runs is reached.

Once data has been recorded it can be downloaded to your PC using DataPro's Recorder features. Connect the Drag-Logger to your PC using the Stack CANUSB interface cable. Connect it to the PC via the USB connector and to the Drag-Logger harness using the 4-way jack plug.

It is possible to put DataPro into download mode prior to the car being available, eg, before it arrives at the pits. Then all that is required to perform the download is to plug the jack into the on-vehicle socket. Data will be transferred to the PC immediately the connection is made.

! *For further details please refer to the Stack DataPro documentation.*

Calibrating Sensors

Certain sensors should be calibrated so that their recorded data is displayed correctly once downloaded to DataPro. The following parameters will need to be calibrated:

Parameter	Calibration
Wheel speed	Match the Wheel Circumference to the value set in the Drag-Logger's Configuration mode
G sensors	Set the zero point for each G sensor with the race ready vehicle standing on a level surface
Suspension sensors	Set the zero point for each suspension sensor with the race ready vehicle standing on a level surface
Pedal positions: Throttle, Brake etc	Set the values for resting and fully depressed pedal positions
Steering position	Set the 90° left and 90° right steering wheel positions

- ! *For further details please refer to the Stack DataPro Designer documentation.*

Appendix A. Main Wiring Harness

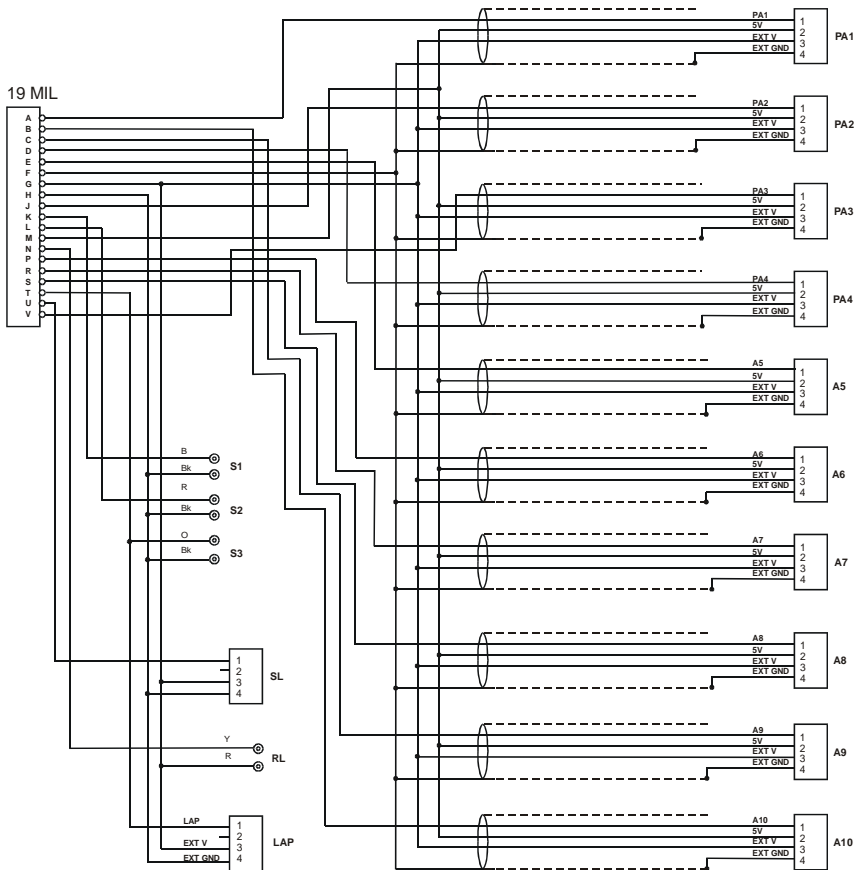

PA1 - PA4 & A5 - A10

Pin 1 White
 Pin 2 Orange
 Pin 3 Red
 Pin 4 Screen

Appendix B. Sensor Wiring Harnesses

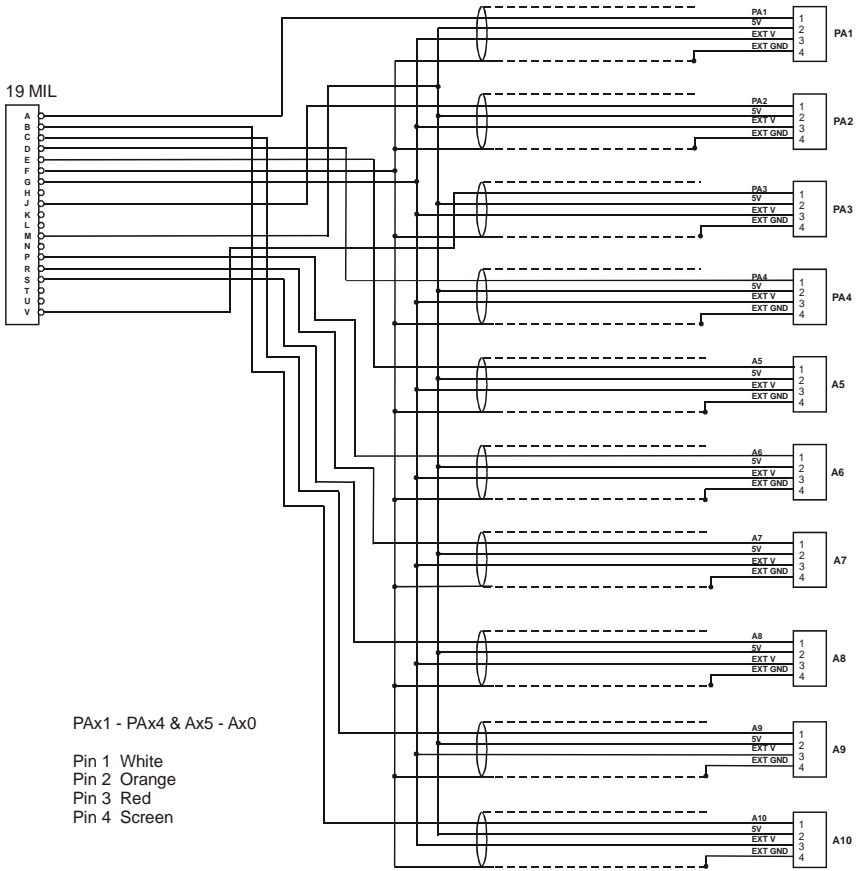

Appendix C. Network Wiring Harness

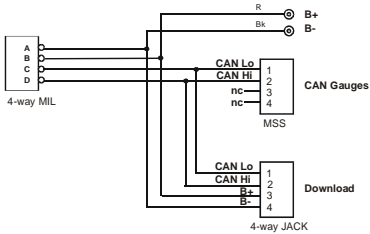

Appendix D. Switch Functions

Standard Functions	Switch
Toggle recording	Switch 2

Gauge Functions	Switch
Cancel alarms (if alarms are active) or Show Peak Values	Switch 1
Toggle day/night illumination level	Switches 1 & 2
Reset Peak Values	Switches 1 & 3

Appendix E. Light Functions

Function	Light
Recording = illuminated	Recording light
Engine speed above shift set-point	Shift light

Appendix F. Service and Support

Service

For service send your product to Auto Meter in a well packed shipping carton. Please include a note explaining what the problem is along with your phone number. Please specify when you need the product back. If you need it back immediately mark the outside of the box "RUSH REPAIR", and Auto Meter will service product within two days after receiving it. (\$10.00 charge will be added to the cost of "RUSH REPAIR.") If you are sending product back for Warranty adjustment, you must include a copy (or original) of your sales receipt from the place of purchase.

12 Month Limited Warranty

Auto Meter Products, Inc. warrants to the consumer that all Auto Meter High Performance products will be free from defects in material and workmanship for a period of twelve (12) months from date of the original purchase. Products that fail within this 12 month warranty period will be repaired or replaced at Auto Meter's option to the consumer, when it is determined by Auto Meter Products, Inc. that the product failed due to defects in material or workmanship. This warranty is limited to repair or replacement of parts in the Auto Meter instruments. In no event shall this warranty exceed the original purchase price of the Auto Meter instruments nor shall Auto Meter Products, Inc. be responsible for special, incidental or consequential damages or costs incurred due to the failure of this product. Warranty claims to Auto Meter must be transportation prepaid and accompanied with dated proof of purchase. This warranty applies only to the original purchaser of product and is non-transferable. All implied warranties shall be limited in duration to the said 12 month warranty period. Breaking the instrument seal, improper use or installation, accident, water damage, abuse, unauthorized repairs or alterations voids this warranty. Auto Meter Products, Inc. disclaims any liability for consequential damages due to breach of any written or implied warranty on all products manufactured by Auto Meter.

For Service Send To: AUTO METER PRODUCTS , INC.
413 W. Elm St., Sycamore, IL 60178 USA (866) 248-6357

Email us at service@autometer.com
<http://www.autometer.com>

Index

- A1 wiring harness, 6
- A2 wiring harness, 6
- alarms, 26
- B1 wiring harness, 6
- B2 wiring harness, 6
- calibrating sensors, 30
- CANUSB, wiring label, 6
- checks and alarms, 29
- clearing an alarm, 27
- configuration, 28
- configuration memory, 28
- contact breaker connection, 15
- data logging, 29
- drag-logger module, 5
- Dual-Lock, 10
- EGT sensor, 19
- electronic ignition), 15
- engine control unit), 15
- engine speed (RPM), 14
- engine speed (RPM), label, 6
- exhaust gas temperature, 19
- fitting drag-logger module, 10
- fluid pressure sensor, 17
- fluid temperature sensor, 18
- gate value, 25
- gear shift light, 13
- gear shift light, wiring label, 6
- gear shift warning light, 1
- hydraulic pressure sensor, 21
- installing CAN gauges, 25
- installing the Drag-Logger, 10
- labels on wiring, 6
- light functions, 33
- linear displacement sensor, 21
- main wiring harness, 31
- multi-stage shift light, 14
- network wiring harness, 33
- optional components, 4
- peak values, 25
- peak values, resetting, 25
- performance parameters, 1
- points connection, 15
- position sensor, 19
- power supply, 8
- proximity sensors, 16
- recording data, 29
- recording light, 12
- recording light, wiring label, 6
- resetting the peak values, 25
- resistor connection to coil, 15
- RPM gate value, 25
- sensor wiring harness, 32
- service and support, 34
- shift light, multi-stage, 14
- shift light, single, 13
- shift lights, 13
- single shift light, 13
- standard components, 3
- switch functions, 33
- switches, 11
- switches, wiring label, 6
- tell tales, 25
- throttle position sensor, 19
- tools needed, 10
- transmission sensors, 16
- unpacking, 3
- vacuum sensor, 17
- wheel speed sensors, 16
- wires in the harness, labels, 6
- wiring harness, 6
- wiring harness, installation, 23